

## 6. Display Cases – refrigerated

for self-service



# Snack-Counter DISPENSER

Refrigerated self-service display case for beverage bottles



### Self-service display case for the sale of beverages

- Always high product pressure because bottles are always fronted to the shelf edge (bottle slide)
- Sales capacity up to 210/315 bottles
- Bottles can be easily removed (self-service)
- Highly luminous and energy-saving LED lighting for good product illumination
- Can be combined with other refrigerated display cases of the series SNACK-COUNTER
- Available in two lengths



The illustrated counter furniture and the illustrated accessories are not included in delivery.

### Increase your sale of beverages –

and offer cooled drinks directly from the counter. This is simply possible with the Snack-Counter DISPENSER.

As soon as the Snack-Counter DISPENSER is fully loaded with beverages, then the bottles can be sold very easily. The customer removes a bottle and the immediately slipping bottles ensure a permanently high product pressure at the sales front.

The Snack-Counter DISPENSER accommodates up to 315 beverage bottles. The highly luminous LED lighting presents the cooled beverages effectively.

### Snack-Counter 520 E DISPENSER-AS lockable



The fill level of the display case can be checked easily from the operator side. The refilling is also carried out from the operator side. After opening the wing doors, the bottles are simply placed on the merchandise display. Then they slide on the bottle slide to the customer's side as far as possible.





With the lane dividers, which are included in delivery, each bottle lane can be individually adapted to the width of the different types of bottles. The upper shelf is height-adjustable so that bottles can be stored in the lower level with a height of up to 30 cm.

With the compact dimensions, the Snack-Counter DISPENSER fits to the refrigerated display cases of the series SNACK-COUNTER.





Thus, the Snack-Counter DISPENSER can be combined, for example, with cooled or uncooled serve-over display cases, with refrigerated or uncooled self-service display cases, with heated display cases or even uncooled display cases of the same design.

The lockable variant **Snack-Counter DISPENSER-AS** (picture on the left) can be used when the shop area is open to permanent traffic and closing times must be considered, for example in airports and train stations.

6  
Self-Service  
Display Cases

Snack-Counter DISPENSER	For external cooling unit incl. controller	With cooling unit and controller	Width [mm]	Cooling power [-10°ET]	Connection
					
Self-service version Height glass top 520 mm	angled	angled			
Snack-Counter 520 E DISPENSER 2	30360	30362	750	890 W	230V/940W 
Snack-Counter 520 E DISPENSER 3	30361	30363	1075	950 W	230V/960W 

Protective machine cover and condensate pan/drain trap are available as accessories.

Snack-Counter DISPENSER-AS, lockable	For external cooling unit incl. controller	With cooling unit and controller	Width [mm]	Cooling power [-10°ET]	Connection
					
Self-service version Height glass top 520 mm	angled	angled			
Snack-Counter 520 E DISPENSER-AS 2	30000	30010	750	890 W	230V/940W 
Snack-Counter 520 E DISPENSER-AS 3	30001	30011	1075	950 W	230V/960W 

Protective machine cover and condensate pan/drain trap are available as accessories.

## Special Accessories

	Art.-No.		Art.-No.
Condensate pan mounted under the cooling unit	33196	Divider bar for bottle slide 520	26457
Drain fitting 1 1/4" for connection to the customer's drain	3815	Divider bar for bottle slide 770	26458
Protective machine cover type 890-950	33195	Set of price label rails for SC DISPENSER 2	26449
Wing doors on the operator side, lockable	30005	Set of price label rails for SC DISPENSER 3	26450

**6**  
Self-Service Display Cases

## Description

Refrigerated display case with circulating air and two display levels for the self-service sale of refrigerated beverage bottles.

Open on the customer side and with angled glass construction made of safety glass. Inclined merchandise shelves with bottle slide frame. The upper shelf is height adjustable.

Temperatures < 7°C at 25°C/60% relative humidity (climate class 3 according to DIN EN ISO 23953).

Commercial product for the installation in stationary food and service counter.

## Design

Construction, merchandise display and interior pan are made entirely of stainless steel, material 1.4301. Recessed inner pan is finished with 1 1/4" flush threaded drain fitting. Pressure-injected expanded polyurethane insulation. Inside the pan is a generously sized circulating air evaporator with coated surface and quiet low-voltage ventilators (12 V DC) for air circulation.

Located above the circulating air evaporator is a merchandise display that is inclined towards the customer and is made of ground stainless steel material 1.4301.

A stable bottle slide frame is placed on this merchandise display. Bottle slide frame is equipped with slot holes for inserting the divider bars to fit the product range.

After the lower merchandise display with the bottle slide frame has been removed, the circulating air evaporator with the ventilators can be folded upwards and locked in the top position via gas pressure springs to clean the pan bottom. The evaporator can be folded down and away from the merchandise display for easy cleaning (MOVE-DOWN FUNCTION).

The glass panel in the area of the lower bottle removal is made of safety glass, which is edged at the top with an impact protection rail made of stainless steel. The side glass panes, the upper glass pane and the upper glass pane on the customer side are also made of safety glass.

For good illumination, a shielded LED light (standard colour: white) is mounted above each shelf. The LED lights are equipped with a transparent protective cover. The mounting lip makes the installation of the refrigerated display case easy. The installation of an additional stable base in the counter design must be taken into account by the customer.

A digital defrosting and temperature controller is mounted beneath the cooling pan. Two air speeds can be selected for different foods. The flat control panel (installation depth: approx. 20 mm) can be removed for mounting in the counter front (cable length: approx. 1 m).

**With WIHA-LONG-LIFE for a longer operating life of the cooling unit.**

The operator side has wing doors made of insulating glass.

### Version AS (lockable):

To lock it, the safety glass pane that is fixed in an upper guide is pulled forward, lowered onto the self-service opening and finally locked. The wing doors on the operator side can also be locked.

### For external cooling unit

Delivery includes:

- Expansion valve for R452A; other refrigerants available on request
- Digital defrost and temperature controller
- 10 pieces/15 pieces U-shaped divider bars

## Cooling Unit Model

The cooling unit is enclosed in a stainless steel housing and is located beneath the cooling pan. It is easy to remove for servicing.

A condensate pan is available as accessory.

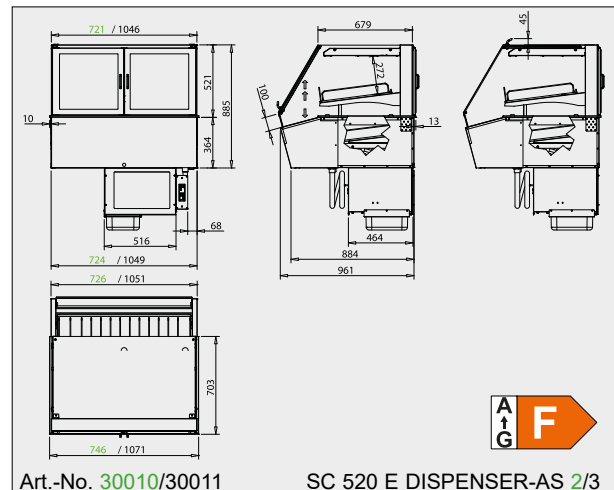
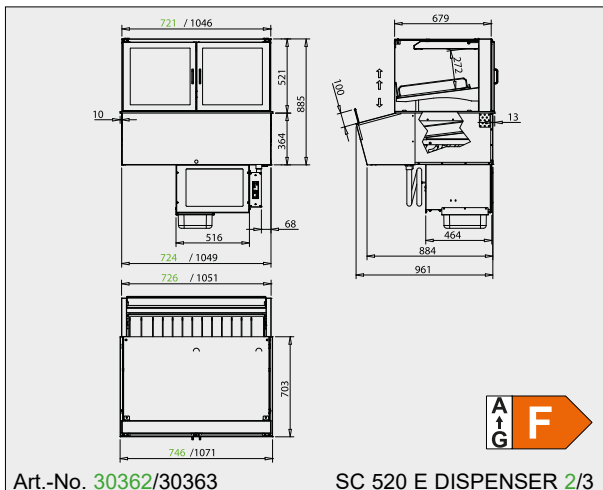

The drawings are shown with special accessory that is not included in the scope of delivery; more drawings are available on [www.wiha-web.com](http://www.wiha-web.com) under "Info Centre / Customer Area".