

Snack-Counter 430 KO-VT-RG

Self-service version, open on customer side with recessed cooling pan and closed rear panel

WiHA
Toughened Safety Glass
The front pane, side panes and glass shelves are made of toughened safety glass.

WiHA
MOVE-DOWN
Patented

WiHA
MOVE-AWAY
Patented

WiHA
LED
energy-saving & low-maintenance



WiHA
LONG-LIFE
Longer operating life of the cooling unit

WiHA
SPLIT-CONTROL
(Special Accessory)
Flat and removable control panel

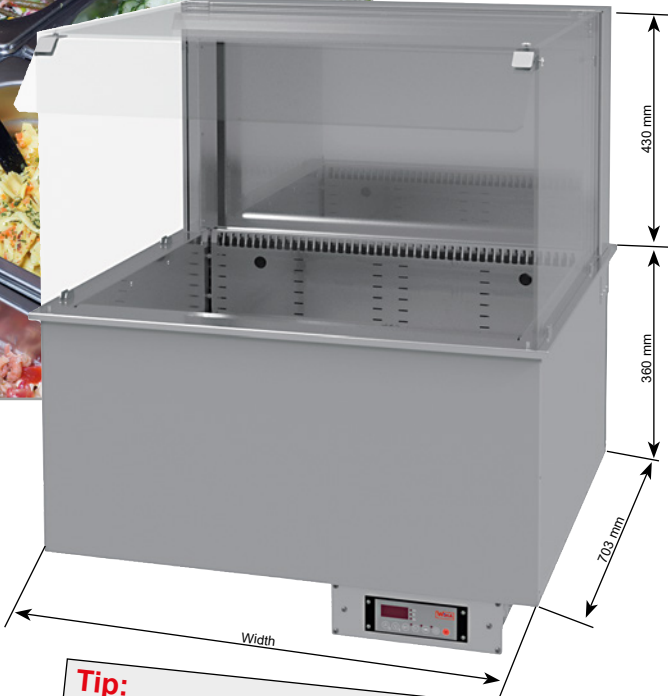







6
Self-Service Display Cases

Base element UTB 51 optionally available, see table on page 386.

Snack-Counter 430 KO-VT-RG

- Optical duplication of the goods by the mirrored rear panel
- With highly luminous LED lighting
- Suitable for 50 mm to 150 mm deep GN pans
- Height-adjustable shelf available as on option

Tip:
This refrigerated display case for self-service can be perfectly combined with the heated display case Snack-Counter STEAM 430 KO-VT-RG on page 270.

Snack-Counter 430 KO-VT-RG	For external cooling unit incl. controller	With cooling unit and controller	Width [mm]	Cooling power [-10°ET]	Connection
	 angled	 angled			
Self-service version Height glass top 430 mm					
Snack-Counter 430 KO-VT-RG - 1.5	33207	33211	585	370 W	230V/325W 
Snack-Counter 430 KO-VT-RG - 2	33208	33212	748	370 W	230V/325W 
Snack-Counter 430 KO-VT-RG - 3	33209	33213	1072	370 W	230V/340W 
Snack-Counter 430 KO-VT-RG - 4	33210	33214	1398	450 W	230V/400W 

Condensate pan/drain trap are available as accessories.

Special Accessories

Condensate pan, loose
Drain fitting 1 1/4" for connecting to the customer's drain

Art.-No.
3819
3815

Bearing rails for GN containers and shelves
Snack-Counter size per GN 1 (1 pair)
Snack-Counter size per GN 1.5 (1 pair)

Art.-No.
6158
10507

Note: GN 1/1 and GN 2/4 containers can be mounted directly, for smaller GN containers additional separator bars are required:
Separator bar GN 1/1 lengthwise with fixed position in the GN 1/1 grid **6219**
Separator bar GN 1/1 lengthwise 530 mm **1025**
Separator bar GN 1/1 crosswise 325 mm **3010**
Separator bar GN 1/3 lengthwise with fixed position **6212**

Note: GN 1/1 and GN 2/4 containers can be mounted directly, for smaller GN containers additional separator bars are required.
Display shelf, unperforated; width=325 mm, GN 1 **6218**
Display shelf, unperforated; width=486 mm, GN 1.5 **10506**
(Bearing rails must be ordered separately.)

Suitable price label rails are available on request.

6. Display Cases – refrigerated

for self-service



Description

Refrigerated display case with circulating air for cooling food in GN containers (50–150 mm deep) or on display shelves, which are available optionally. Version with recessed cooling pan and closed rear panel with mirror for an optical multiplication of the goods. The customer side is open and with angled glass construction made of safety glass. Temperature: 7°C at 25°C/60% relative humidity (climate class 3 according to DIN EN ISO 23953). Humidity: approx. 70% to 85%. Commercial product for the installation in stationary food and service counter.

Design

Construction, merchandise display and interior pan are made entirely of stainless steel, material 1.4301. Recessed inner pan is finished with 1 1/4" flush threaded drain fitting and hygienic corners that are easy to clean. Pressure-injected expanded polyurethane insulation. The exterior is made of galvanised sheet steel. Inside the pan is a generously sized circulating air evaporator with coated surface and quiet low-voltage ventilators (12 V DC) for air circulation.

The vertical walls above the evaporator are equipped with a perforation for vertically adjustable bottom beams (available as accessories). Gastro-Norm containers (50–150 mm deep) can be mounted or display shelves (available as accessories) can be inserted.

To clean the pan bottom, the merchandise display with circulating air evaporator and ventilators can be folded upwards and locked in the top position via gas pressure springs. For easy cleaning of the evaporator, it can be folded down (MOVE-DOWN TECHNOLOGY) when the merchandise display

is open. To clean the area behind the pan or to carry out servicing, the merchandise display can be moved forwards (MOVE-AWAY FUNCTION).

The rear wall is made of safety glass and includes a mirror for an optical multiplication of the goods. For good illumination, a shielded LED light (standard colour: white) is mounted above each shelf. The shelves are suitable for Gastro-Norm dimensions. The mounting lip makes installation easy.

A digital defrosting and temperature controller is mounted beneath the cooling pan. Two air speeds can be selected for different food. The flat control panel (installation depth: approx. 20 mm) can be removed for mounting in the counter front (cable length: approx. 1 m).

With WIHA-LONG-LIFE for a longer operating life of the cooling unit.

For external cooling unit

- Delivery includes:
- Expansion valve for R134a/R513A
 - Digital defrost and temperature controller

Cooling Unit Model

The cooling unit is fully pre-assembled and is connected to the cooling pan with refrigerant couplings.

Please note:
The counter design should include a well-ventilated base unit beneath the refrigerated display case.

6
Self-Service
Display Cases

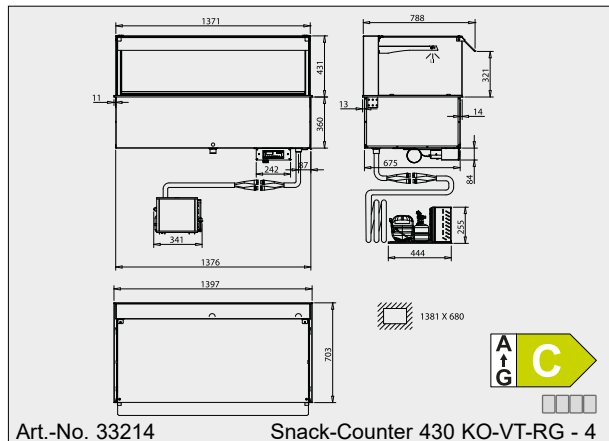
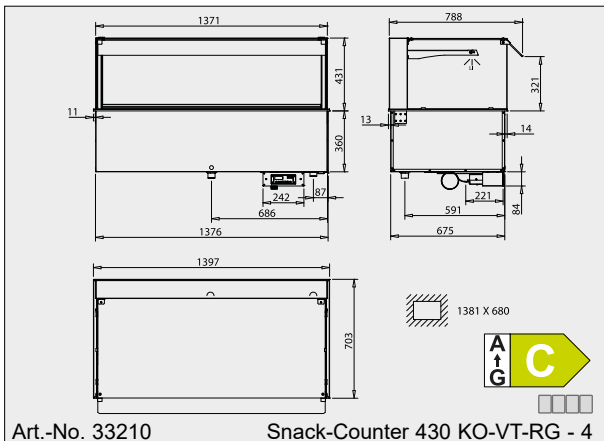
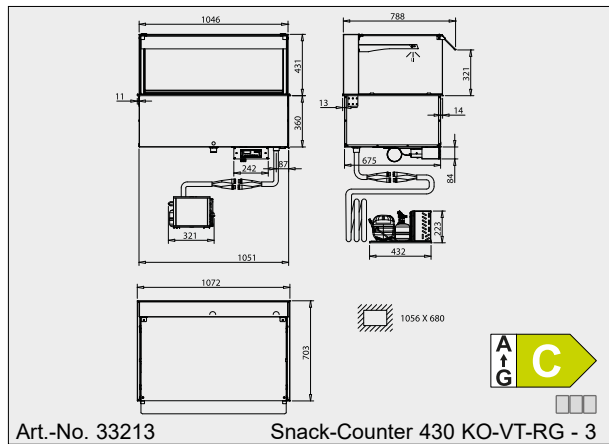
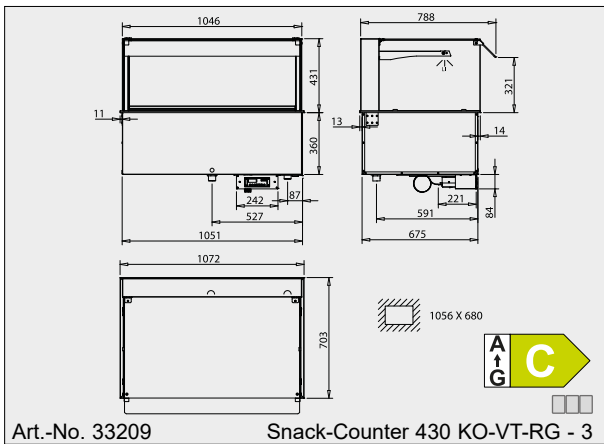
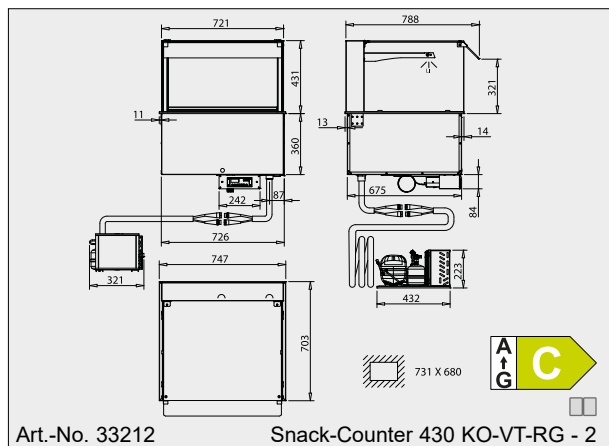
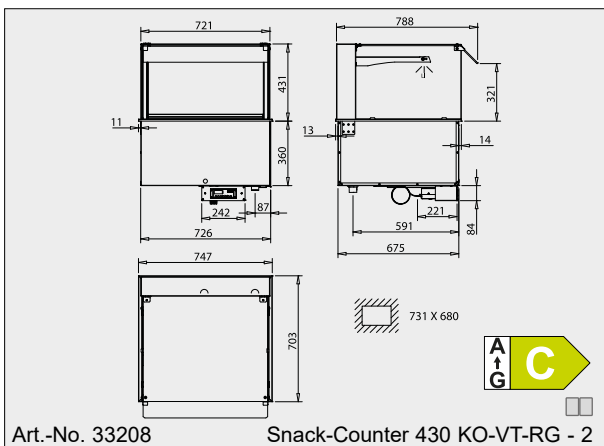

More drawings are available on www.wiha-web.com under "Info Centre / Customer Area".