

## Work Station SST

For worktop mounting

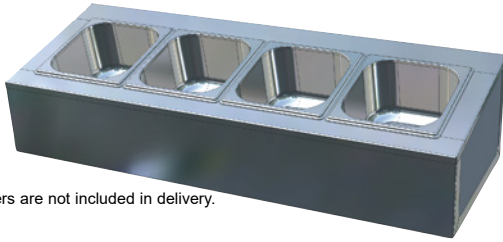

GN containers are not included in delivery.

### Description

Cooling pan with contact pipes for cooling merchandise in Gastro-Norm containers. Temperature range: 4°C to 12°C (climate class 3 according to DIN EN ISO 23953; 25°C, 60% RH.; Gastro-Norm container sealed with a lid)  
Commercial product for the installation in stationary food and service counter.

### Design

Interior and exterior are made entirely of stainless steel. The insulation is made of polyurethane (CFC-free). The external visible sides have a fine surface finish.

For external cooling unit:

On the base is a sleeve for the insertion of a temperature sensor. The expansion valve should be provided on the exterior.

### Cooling Unit Model

The cooling unit is fully pre-assembled and is connected to the cooling pan with refrigerant couplings. It comes with the TMP 350 built-in controller that is connected to the cooling unit and cooling pan via cable connectors. The condensate hose must be connected on site to the drain or a condensate pan must be provided on site by the customer. The expansion valve is mounted underneath the cooling pan.

**4**  
Static Cooling Systems

WIHA Work Station SST Model	For external cooling unit Art.-No.	With cooling unit and controller Art.-No.	Width [mm]	Depth [mm]	Height pan [mm]	Cooling power [-15°ET]	Connection cooling unit
SST 1/6-4	3602 *	33181	713	252	169	120 W	230V/230W
SST 1/6-6	3603 *	33182	1037	252	169	120 W	230V/230W
SST 1/6-8	3960 *	3964	1361	252	169	200 W	230V/230W

GN containers are not included in delivery.

\* The expansion valve shall be provided externally.

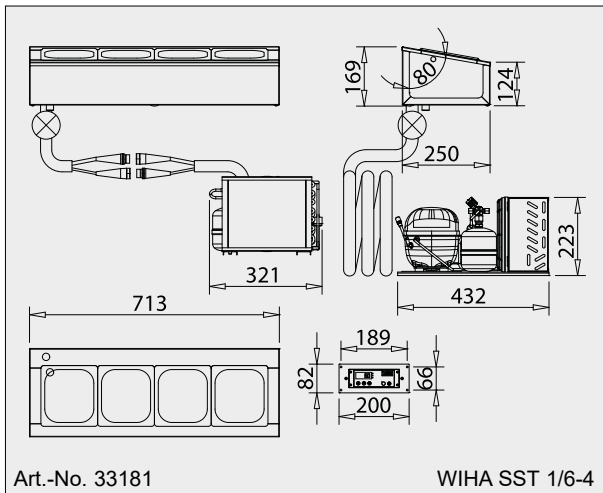

### Special Accessories

	Art.-No.
Gastro-Norm container GN 1/6-100	3639
Lid for GN 1/6 (stainless steel)	3641
TMP 350 controller for external cooling unit	3310

**Tip:**  
Chiller unit with circulating air "Gastro-Snack 5x1/3 and 7x1/3" for cooling merchandise in GN containers see page 32.

### Other sizes available on request.

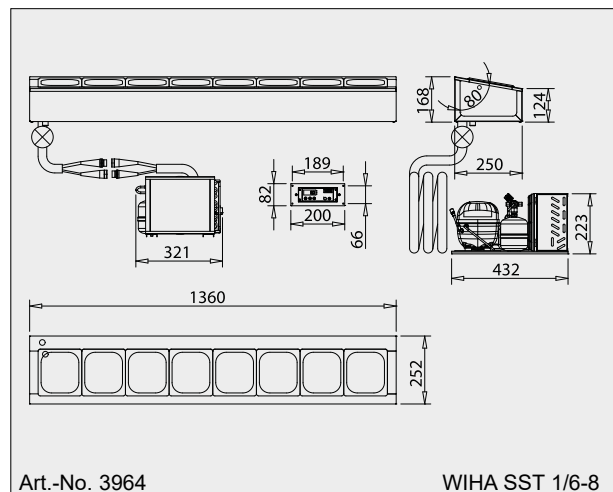
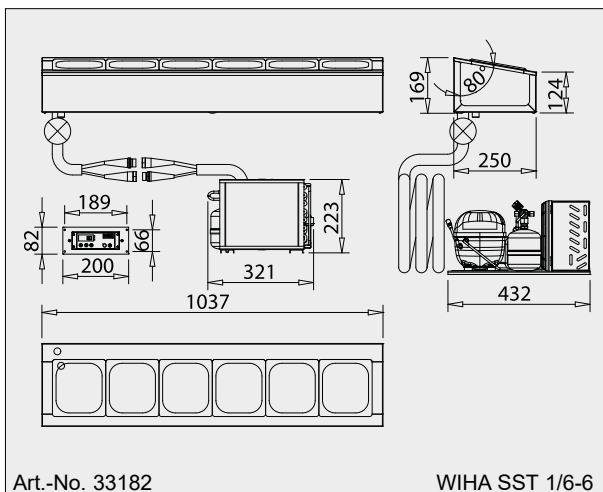

The drawings are shown with special accessory that is not included; more drawings are available on [www.wiha-web.com](http://www.wiha-web.com) under "Info Centre / Customer Area".