

## Tiered Refrigeration Module

### SKE 120 SP IMPULSE

The merchandise display can be inclined for impulse sale

**2**  
Tiered  
Installation

**Freshness System**  
(Special Accessory)  
Patented

**MOVE-UP**  
Better view of the goods for the impulse sale

**ROUND-BOTTOM**  
Easy cleaning of the pan bottom

**MOVE-DOWN**  
\* gas pressure springs

**LONG-LIFE**  
Longer operating life of the cooling unit

**MOVE-AWAY**  
Patented

**SPLIT-CONTROL**  
(Special Accessory)  
Flat and removable control panel

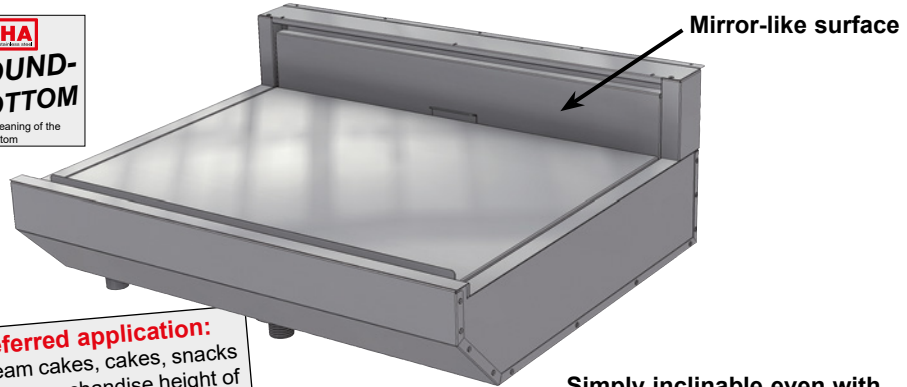

**Preferred application:**  
Cream cakes, cakes, snacks with a merchandise height of up to 12 cm.

adjustable in 2 seconds

Simply inclinable even with loaded merchandise display.

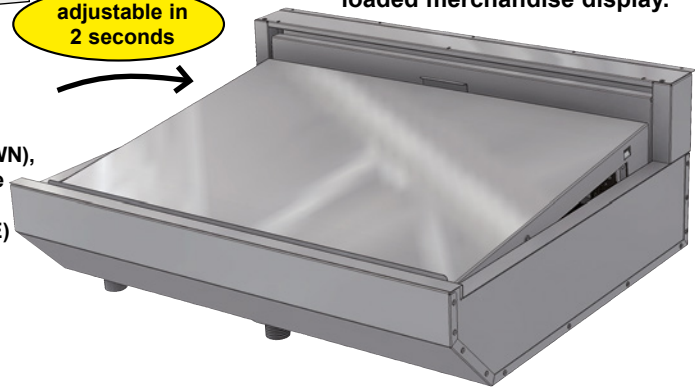

### Food stays fresh for longer thanks to the patented FRESHNESS SYSTEM

- Inclinable merchandise display (MOVE-UP)
- The air cooler can be easily folded down (MOVE-DOWN), in case of R134a/R513A with additional gas pressure springs
- Longer operating life of the cooling unit (LONG-LIFE)
- Hygienic base with round shaped corners (ROUND-BOTTOM)
- 4°C cooling technology
- 2 air speeds
- Liftable evaporator

The horizontal position of the display ensures an ideal climate for cream cakes!

The cold reservoir created by the cascade design is an absolute must for sensitive cream cakes. Along with the large evaporator surface, high humidity is generated for gentle cooling.

**MOVE-UP – stimulate the customer's senses with a better view to raise your turnover**

The MOVE-UP function places the goods closer to the customer. A better sight encourages the customer to purchase the displayed products.

WIHA SKE 120 SP IMPULSE Model	For external cooling unit Art.-No.	With cooling unit and controller Art.-No.	Cooling power [-10°ET]	Connection cooling unit	
SKE 120 SP IMPULSE - 600 *	21843	21844	370 W	230V/270W	■
SKE 120 SP IMPULSE - 800	21800	21803	450 W	230V/350W	■
SKE 120 SP IMPULSE - 1200	21801	21804	605 W	230V/390W	■■
SKE 120 SP IMPULSE - 1600	21802	21805	825 W	230V/540W	■■■
SKE 120 SP IMPULSE - 1600 D (2 air coolers)	21836	21838	825 W	230V/540W	■■■■
SKE 120 SP IMPULSE - 2000 D (2 air coolers)	21837	21839 **	1060 W	230V/750W	■■■■■

The refrigeration units for external cooling units include an expansion valve for R134a/R513A and built-in temperature sensors. Protective machine cover and condensate pan/drain trap are available as accessories.

\* Not available with FRESHNESS SYSTEM.

\*\* Without base element, the cooling unit is connected via refrigerant couplings.

### Special Accessories

	Art.-No.
Condensate pan mounted under the cooling unit	33196
Drain fitting 1 1/4" for connecting to the customer's drain	3815
Reference thermometer TPE 2 for the customer side	2182
TMP 620 controller for external cooling unit	12201
TMP 630 controller instead of TMP 620 with 2 freely usable outputs	12210
Detachable control panel (SPLIT-CONTROL)	12219
extra charge for device with cooling unit in the base housing	
Protective machine cover type 370-825	33194
Protective machine cover type 825 (2 air coolers)	33195
Quick-connect cleaning head (on-site drain is necessary)	6322
Side wall heightening for SKE (The side walls are designed in same height as the height of the customer side.)	6403
DUO-Bridge SKE 120 To connect two adjacent mounted SKE air chiller units.	6405

**Air cooler for operation with refrigerant CO<sub>2</sub>** 10197  
(price per air cooler, design see page 384)

**Patented WIHA FRESHNESS SYSTEM** see page 47.

Base element UTB 51 optionally available, see table on page 386.

### Description

Chiller unit with circulating air for cooling cakes, cream cakes and snacks with a merchandise height of up to 12 cm max (lower position of the merchandise display) or up to 5.5 cm (upper position of merchandise display). The merchandise display can be adjusted horizontally or inclined towards the customer for impulse sale (MOVE-UP FUNCTION). The air baffle located behind the merchandise has a mirror-like surface.

To operate it, the customer should provide a glass top that should only be open on the air blow-off side.

Temperature: < 5°C at 25°C/60% relative humidity (climate class 3 according to DIN EN ISO 23953).

Commercial product for the installation in stationary food and service counter.

See page 48 for design details of the model.

# 2. Air Chiller Units

tiered installation



**2**  
Tiered  
Installation

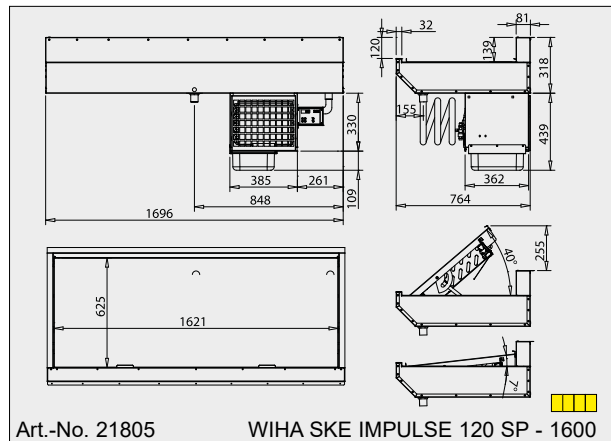
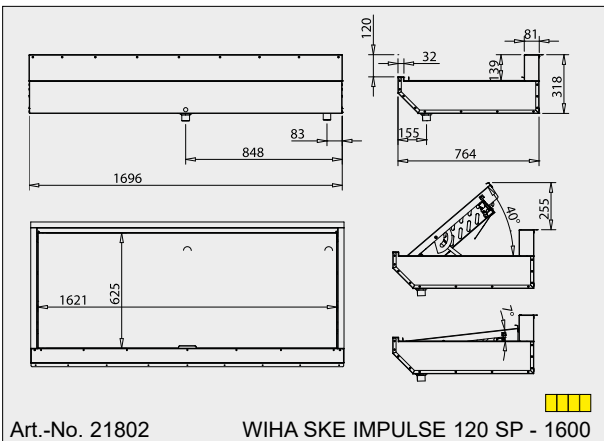
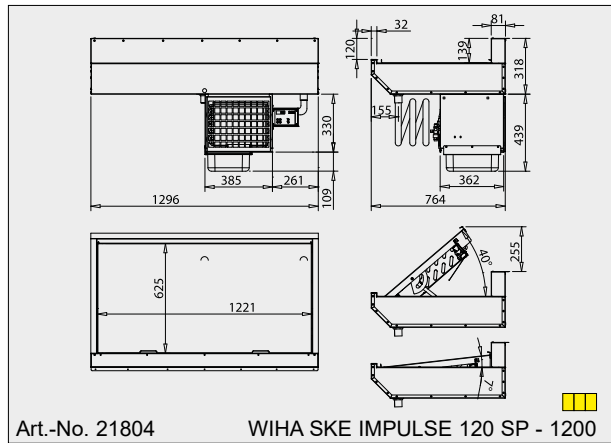
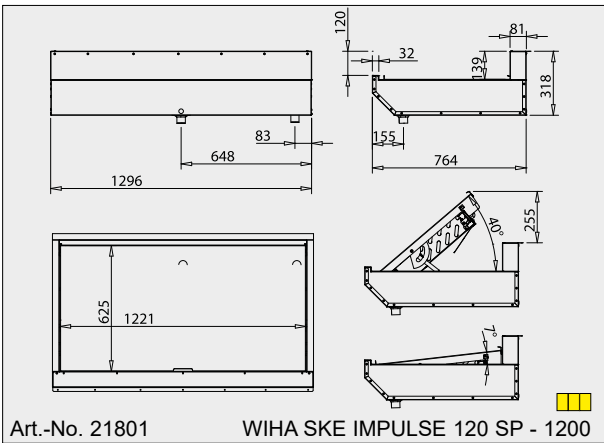
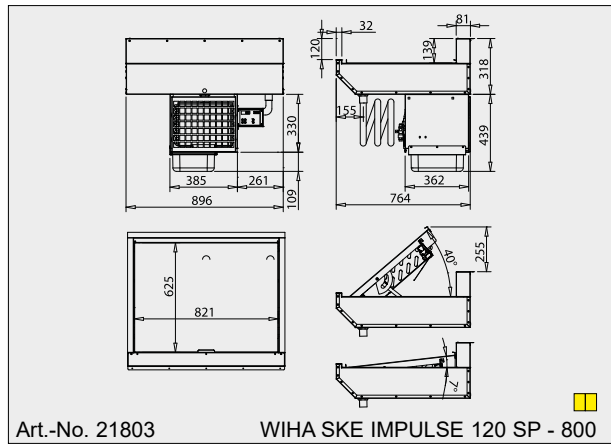
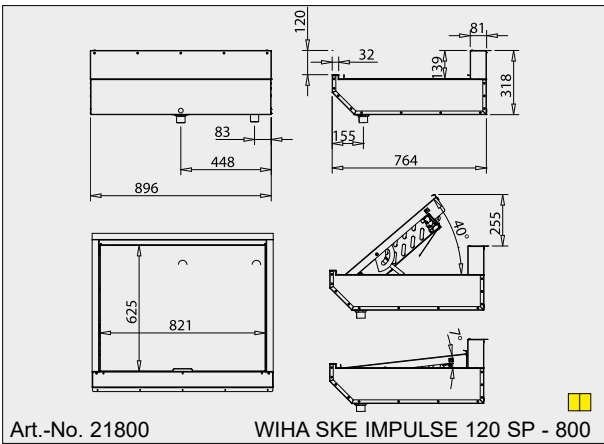
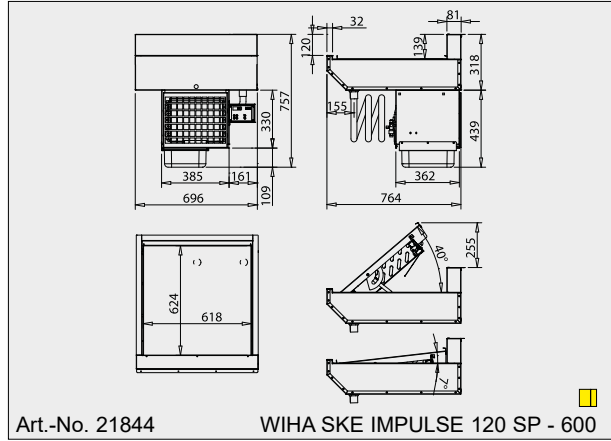
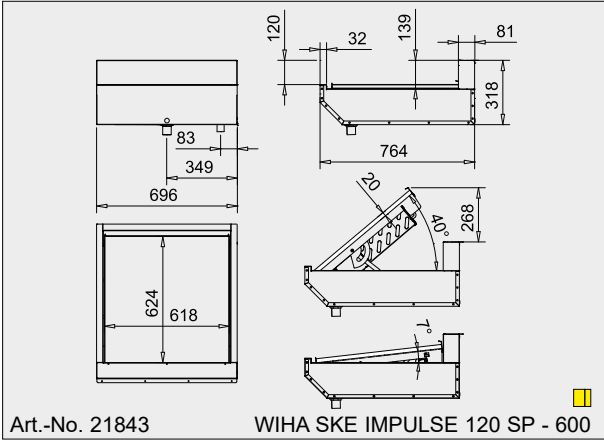

The drawings are shown with special accessory that is not included; more drawings are available on [www.wiha-web.com](http://www.wiha-web.com) under "Info Centre / Customer Area".