

# 5. Display Cases – refrigerated

for serve-over



## Euro-Counter DRAWER

Serve-over version with drawer

**WiHA**  
Freshness System  
(Special Accessory)  
Patented

**WiHA**  
**LED**  
energy-saving & low-maintenance

**WiHA**  
Toughened Safety Glass  
The front pane, side panes and glass shelves are made of toughened safety glass.

**WiHA**  
**LONG-LIFE**  
Longer operating life of the cooling unit

**WiHA**  
**MOVE-DOWN**  
Patented

**WiHA**  
**Soft-Close**  
Soft-closing sliding doors  
Special Accessory

**WiHA**  
**MOVE-AWAY**  
Patented

**WiHA**  
**SPLIT-CONTROL**  
(Special Accessory)  
Flat and removable control panel



**Display case with 3 refrigerated levels for Euro-Norm trays (400 mm x 600 mm)**

Euro-Counter 710 DRAWER BE	For external cooling unit incl. controller			With cooling unit and controller			Width [mm]	Cooling power [-10°ET]	Connection
Serve-over version Height glass top 710 mm	round	angled	slanted	round	angled	slanted			
Euro-Counter 710 DRAWER BE - 800	11220	11222	17312	11224	11226	17314	922	450 W	230V/335W
Euro-Counter 710 DRAWER BE - 1200	11221	11223	17313	11225	11227	17315	1322	605 W	230V/410W

The refrigerated display cases for external cooling units include an expansion valve for R134a/R513A and temperature controller. The FRESHNESS SYSTEM (circulated air disinfection), protective machine cover and condensate pan/drain trap are available as accessories.

### Special Accessories

Condensate pan mounted under the cooling unit  
Drain fitting 1 1/4" for connecting to the customer's drain  
Protective machine cover type 450  
Protective machine cover type 605

**Art.-No.**  
33266  
  
3815  
33194  
33195

Price label rail glass shelf 800  
Price label rail glass shelf 1200  
  
Price label rail lower display area 800  
Price label rail lower display area 1200

**Art.-No.**  
11245  
11246  
  
11492  
11491

Worktop on drawer front 800 11228  
Worktop on drawer front 1200 11229  
Packing paper holder (CNS) 800 11230  
Packing paper holder (CNS) 1200 11231

Option soft-close (soft-closing sliding doors) 4711

Option: Light colour adjustable, see page 141.

Patented **WiHA FRESHNESS SYSTEM** see page 126.

### Description

Refrigerated display unit with circulating air and merchandise drawer for cooling cakes, cream cakes and snacks. On the customer side with rounded, angled or slanted glass construction made of safety glass. The glass shelves are height adjustable and can be set at an angle, which means better presentation.

Temperature: < 7°C at 25°C/60% relative humidity (climate class 3 according to DIN EN ISO 23953). Humidity: approx. 70% to 85%.

Commercial product for the installation in stationary food and service counter.

### Design

Construction, merchandise display and interior pan are made entirely of stainless steel material 1.4301. Pan interior is finished with 1 1/4" flush threaded drain fitting and hygienic corners that are easy to clean. Pressure-injected expanded polyurethane insulation. The exterior is made of galvanised sheet steel. Inside the pan is a generously sized circulating air evaporator with coated surface and quiet low-voltage ventilators (12 V DC) for air circulation. Located above the circulating air evaporator is a merchandise drawer. Drawer on both sides with ball bearing drawer runners (CNS), load capacity up to 100 kg. Drawer cover with upper handle bar.

To clean the pan bottom, the merchandise display with circulating air evaporator and ventilators can be folded upwards on the customer side and locked in the top position via gas pressure springs. The front glass pane is made of safety glass. It can be swung outwards for easy cleaning. The side glass panes and shelves are also made of safety glass. For good illumination, a shielded LED light

(standard colour: white) is mounted above each shelf. The shelves are suitable for Euro-Norm dimensions (400 mm x 600 mm or 400 mm x 300 mm). The mounting lip makes installation easy. A digital defrosting and temperature controller is mounted beneath the cooling pan. The flat control panel (installation depth: approx. 20 mm) can be removed for mounting in the counter front (cable length: approx. 1 m).

**With WIHA-LONG-LIFE for a longer operating life of the cooling unit.**

The operator side, located above the merchandise drawer, has sliding doors made of insulating glass, easily removable for cleaning (without bottom rail).

For external cooling unit

Delivery includes:

- Expansion valve for R134a/R513A
- Defrost and temperature controller

### Cooling Unit Model

The cooling unit is encased in a stainless steel housing and is located beneath the cooling pan. It is easy to remove for servicing.

A condensate pan is available as accessory.

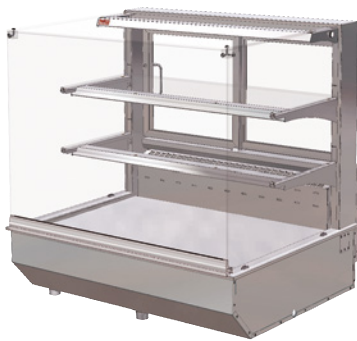

Euro-Counter 710 E (angled)



Euro-Counter 710 S (slanted)

**5**  
Serve-Over  
Display Cases

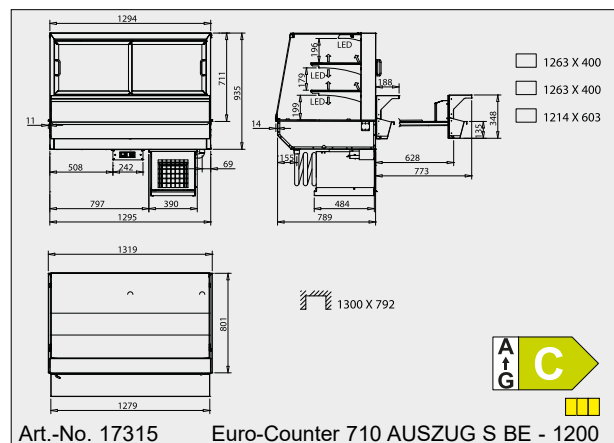
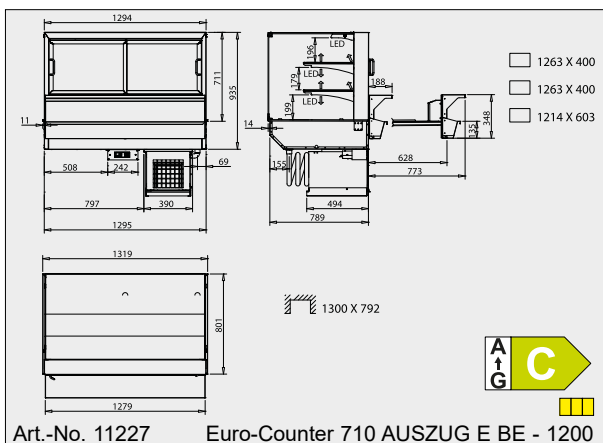
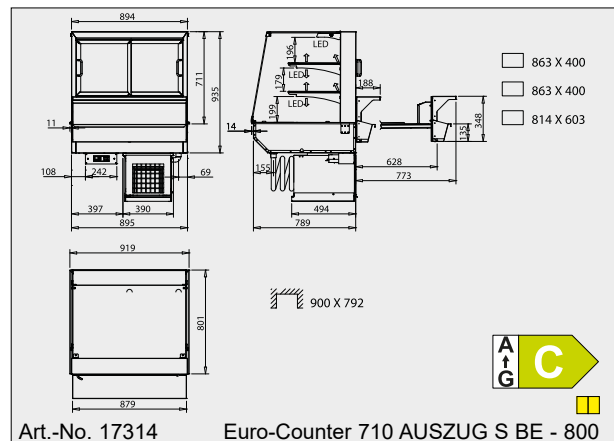
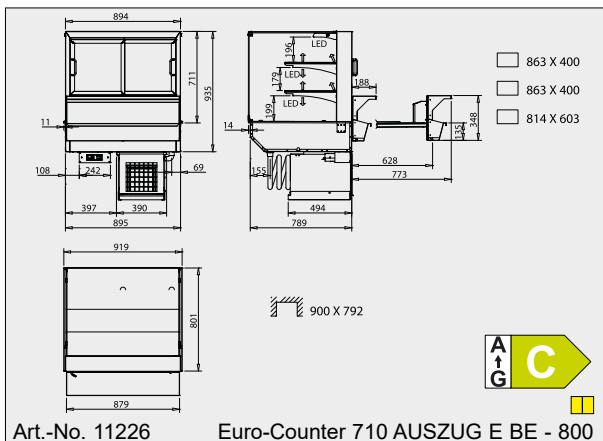

The drawings are shown with special accessory that is not included in the scope of delivery; more drawings are available on [www.wiha-web.com](http://www.wiha-web.com) under "Info Centre / Customer Area".