

5. Display Cases – refrigerated

for serve-over



Euro-Counter 280 E BE SLIDE OUT 1000

Refrigerated display case for cream cakes



Also available in black on request.



Option: Light colour adjustable, see page 141.

Base element UTB 51 optionally available, see table on page 386.

Cakes and pies perfectly presented!

- Perfect insight thanks to a low glass construction
- Practical drawer with soft-close enables a quick and easy operation
- DROP-IN – simple installation from above
- Energy saving double glazing glass construction with bright LED lighting
- Gentle cooling prolongs the freshness of the goods

Optimal presentation with a low glass construction

The Euro-Counter 280 E BE SLIDE OUT 1000 allows your client a perfect insight, especially from above, thank to its low glass construction. In combination with the bright LED lighting, the products are staged in a sales-effective manner on the up to six cakes-capacity drawer.

The view from above will help your client to gain a better overview on the presented selection and will make his choice to become a special experience.



Drawer with SOFT-CLOSE

The drawer is rested on robust and reliable ball bearing mounted rollers for an easy operation. When pushed back into the counter, the additional soft-close feature gently slows down the drawer before arriving in its final position. It is then slowly pulled into the final position.



Bright LED Lighting

The interior is equipped with two stripes of bright LED lights, enabling a perfect illumination of the goods.

Easy Cleaning

After having fully pulled out and removed the drawer and the lower base plates for the merchandise, the evaporator can be lifted up for cleaning or servicing. It is locked in the top position via gas pressure springs. In this position, the pan bottom is also fully accessible for cleaning. The front glass pane can be swung outwards for easy cleaning.

5
Serve-Over
Display Cases

Euro-Counter 280 E BE SLIDE OUT 1000	For external cooling unit with controller	With cooling unit and controller	Width [mm]	Cooling power [-10°ET]	Connection
	 angled	 angled			
Serve-over version Height glass top 280 mm	6350	6351	1122	370 W	230V/330W

Protective machine cover and condensate pan/drain trap are available as accessories.

Special Accessories

Condensate pan mounted under the cooling unit	Art.-No. 33266	Protective machine cover type 370/450	Art.-No. 8179
Drain fitting 1 1/4" for connecting to the customer's drain	3815	Price label rail pull-out drawer 1000	6440
		Price label rail lower display area E-C 1000	33170

Option: Light colour adjustable, see page 141.

Base element UTB 51 optionally available, see table on page 386.

Description

Refrigerated display case with circulating air and merchandise drawer on the operator side for cooling cakes, cream cakes and snacks. The customer side has an angled glass construction made of insulating glazing. Temperature: < 7°C at 25°C/60% relative humidity (climate class 3 according to DIN EN ISO 23953). Humidity: approx. 70% to 85%. Commercial product for the installation in stationary food and service counter.

The glass pane of the drawer is made of safety glass. For good illumination, shielded LED lights (standard colour: white) are mounted above the merchandise drawer. The circumferential mounting lip makes installation easy.

A digital defrosting and temperature controller is mounted beneath the cooling pan. Two air speeds can be selected for different foods. The flat control panel (installation depth: approx. 20 mm) can be removed for mounting in the counter front (cable length: approx. 1 m).

With WIHA-LONG-LIFE for a longer operating life of the cooling unit.

Design

Construction, merchandise display and interior pan are made entirely of stainless steel, material 1.4301. Pan interior is finished with 1 1/4" flush threaded drain fitting and hygienic corners that are easy to clean. Pressure-injected expanded polyurethane insulation. The exterior is made of galvanised sheet steel. Inside the pan is a generously sized circulating air evaporator with coated surface and quiet low-voltage ventilators (12 V DC) for air circulation. Located above the circulating air evaporator is a pull-out merchandise drawer. The merchandise drawer is fitted out with robust stainless steel roller drawers with overlength (load capacity 100 kg). To clean the pan bottom, the lower covers can be removed after the drawer has been pulled out. Then the circulating air evaporator and ventilators can be folded upwards and locked in the top position via gas pressure springs. On the customer side and on the sides, the EURO-Counter SLIDE OUT 1000 is equipped with insulating glazing made of laminated safety glass. The front glass pane can be swung outwards for easy cleaning.

For external cooling unit

Delivery includes:

- Expansion valve for R134a/R513A
- Digital defrost and temperature controller

Cooling Unit Model

The cooling unit is encased in a stainless steel housing and is located beneath the cooling pan. It is easy to remove for servicing. A condensate pan is available as accessory.

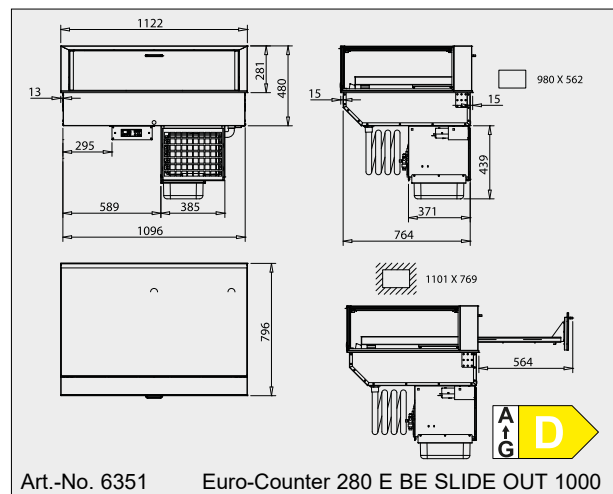
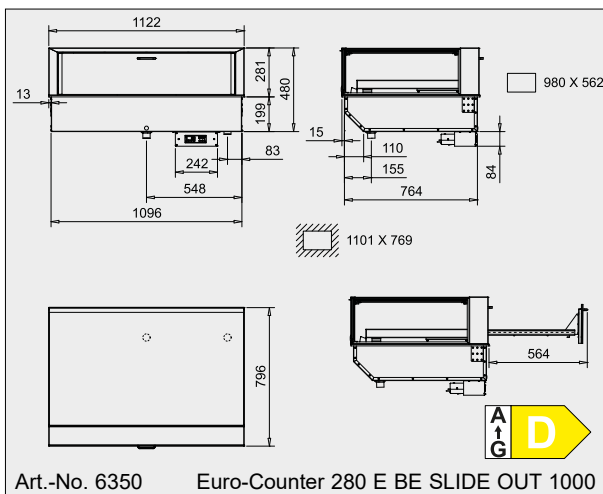

The drawings are shown with special accessory that is not included in the scope of delivery.